

WANDLER





























































































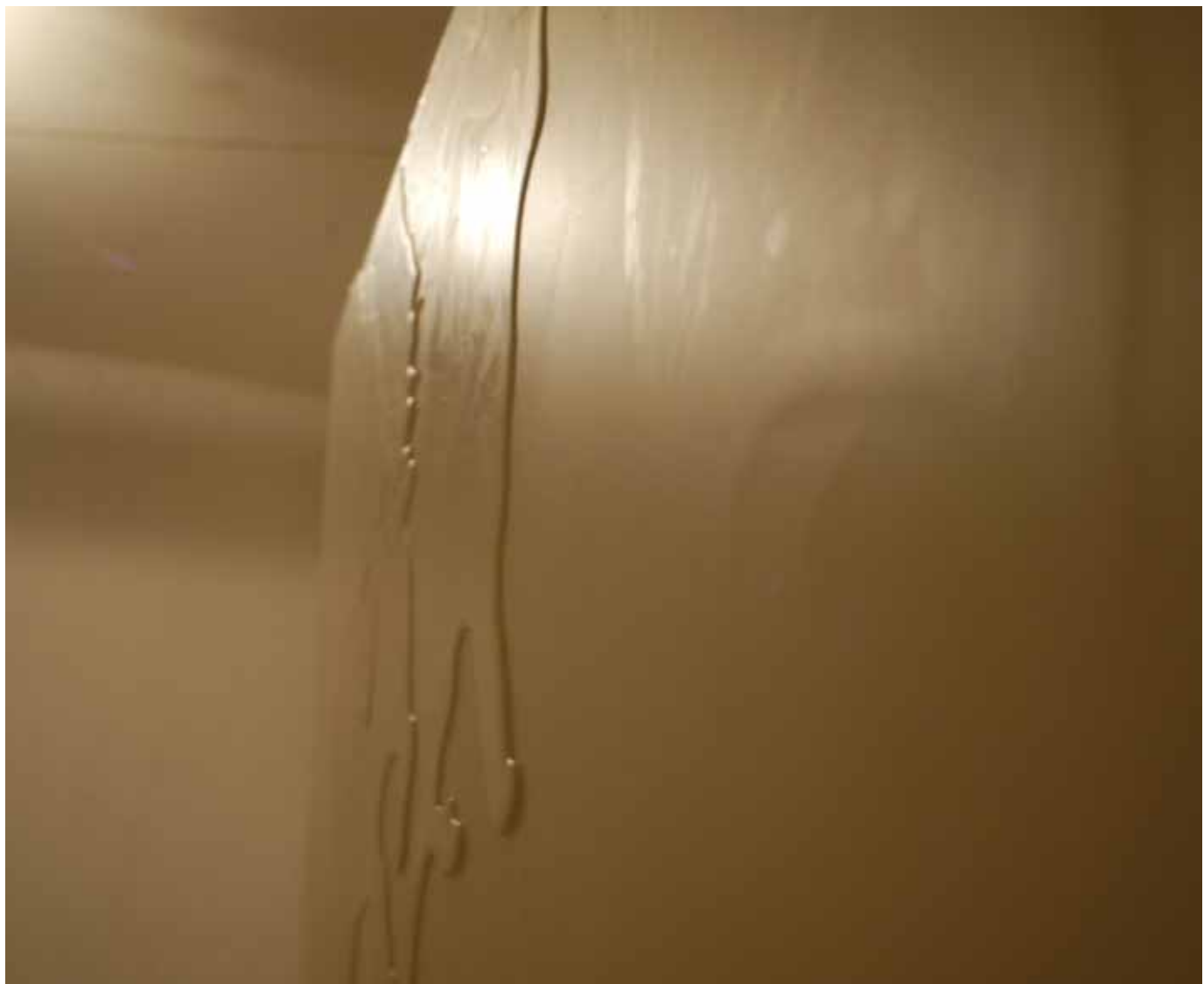



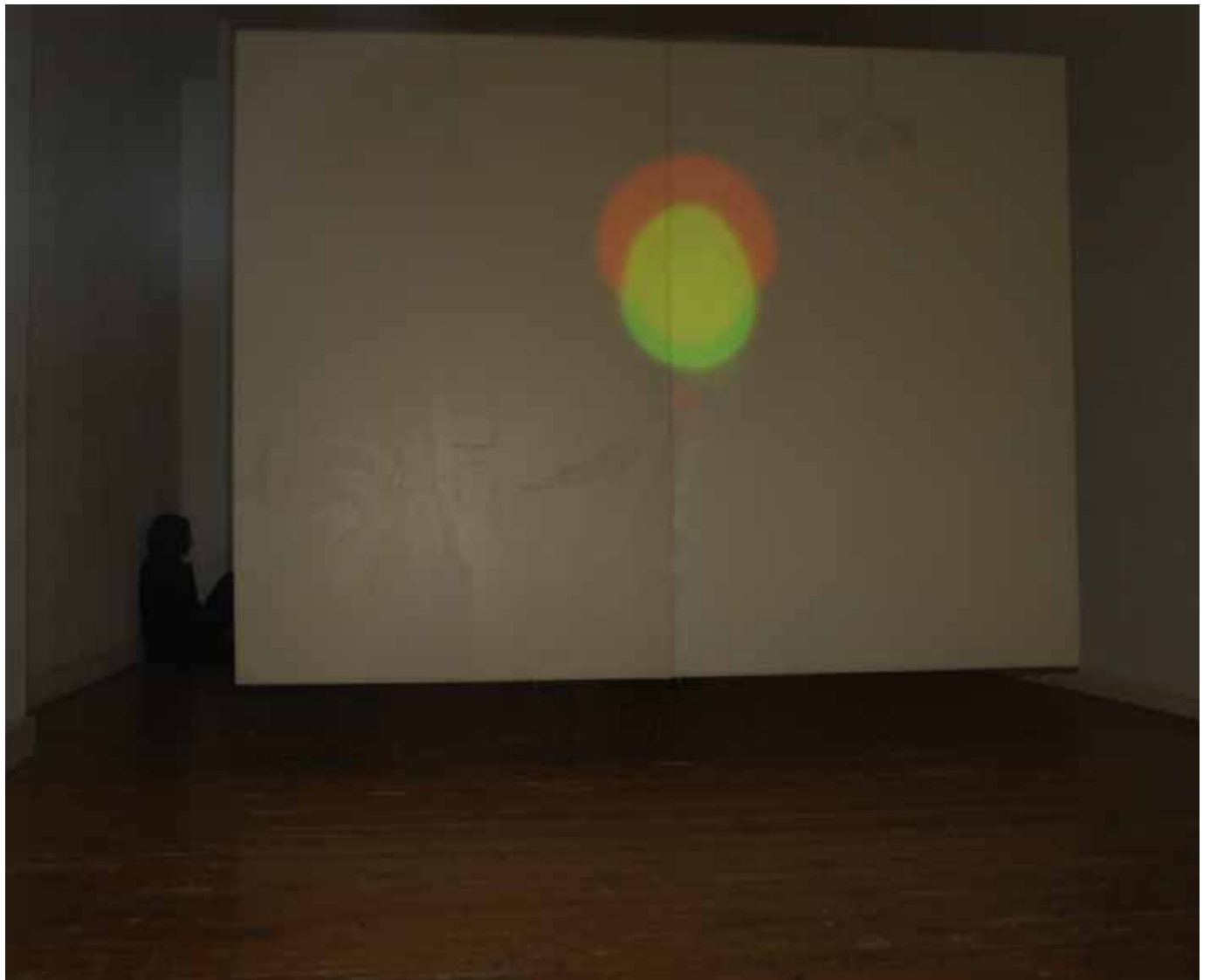

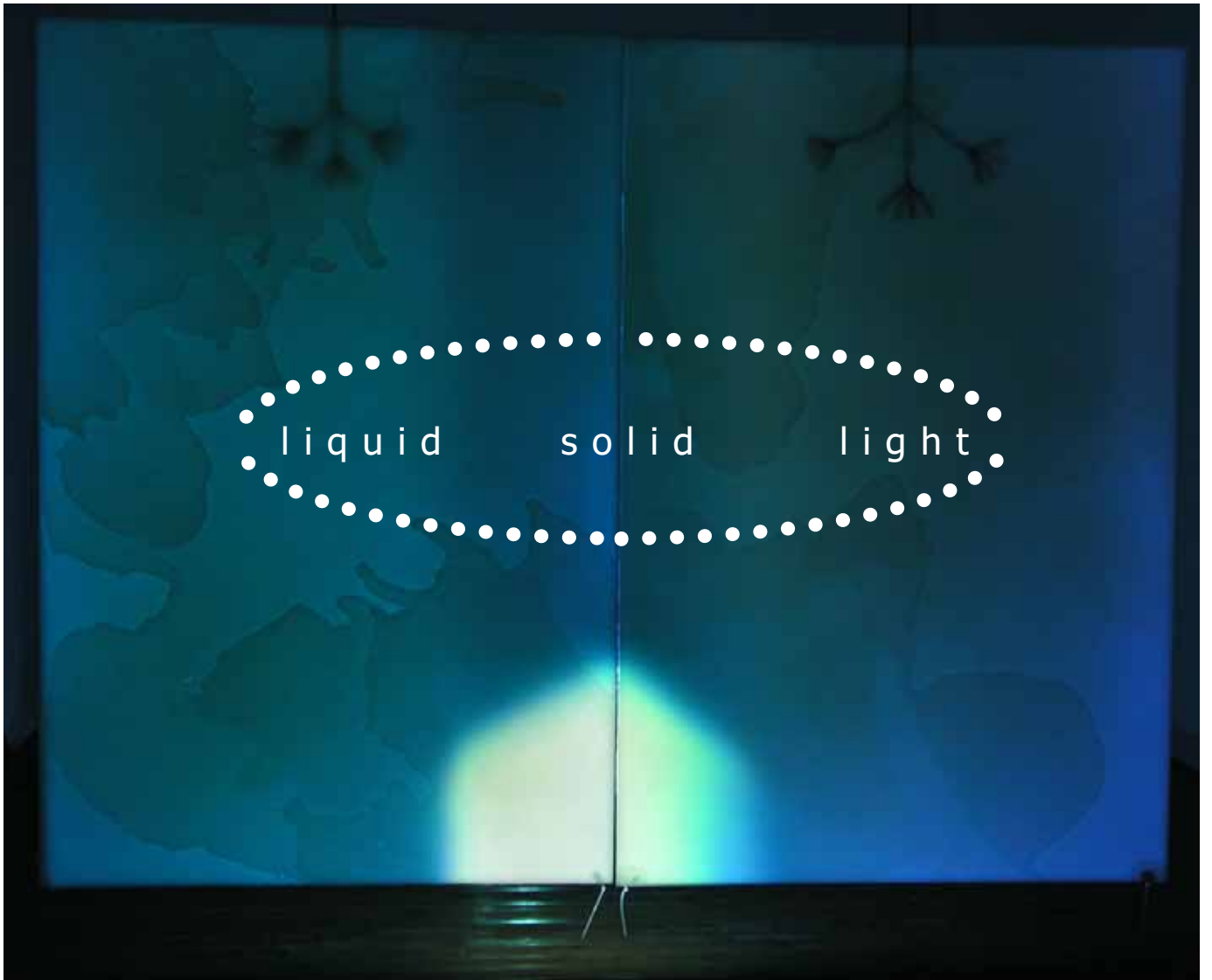

liquid

solid

light

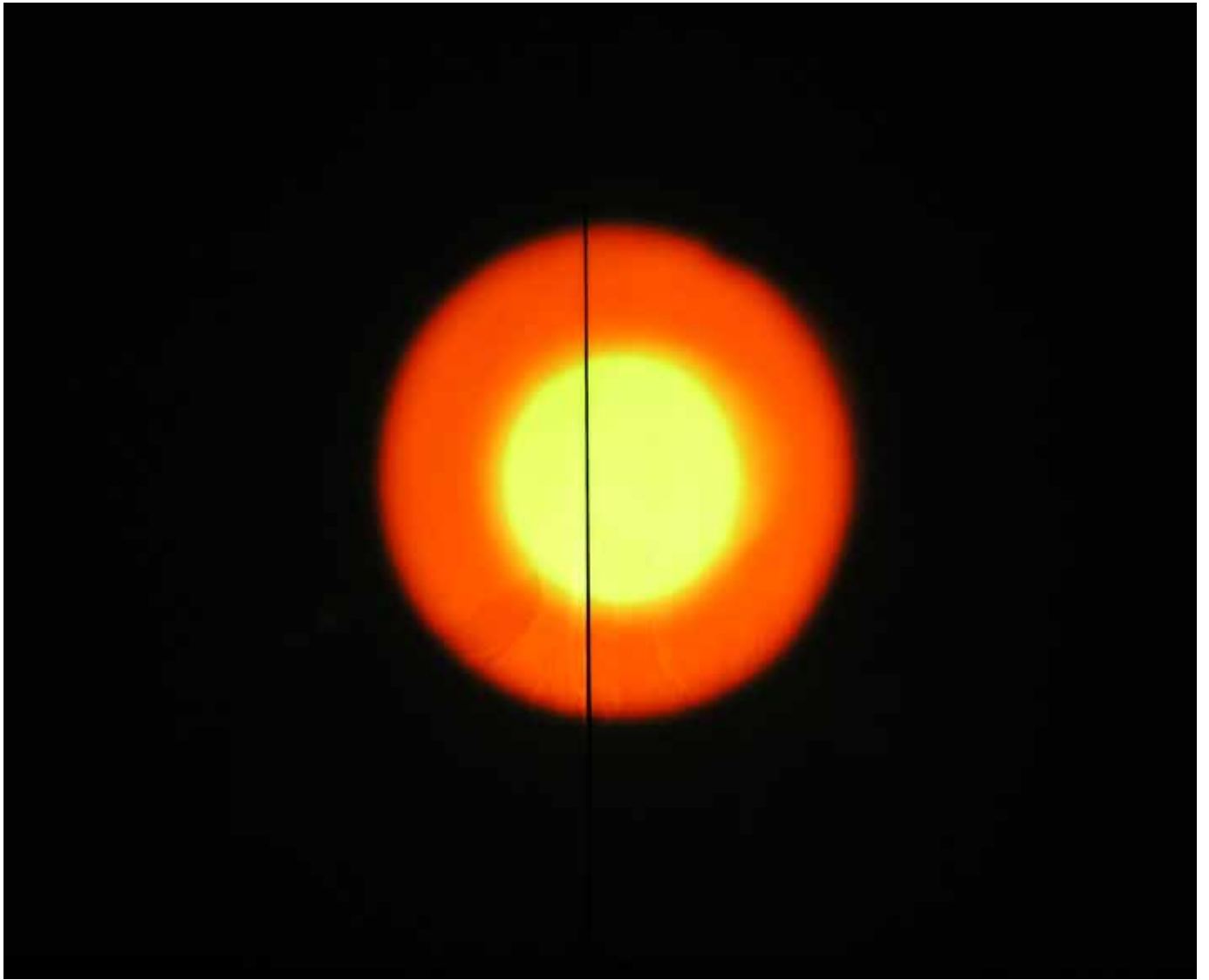

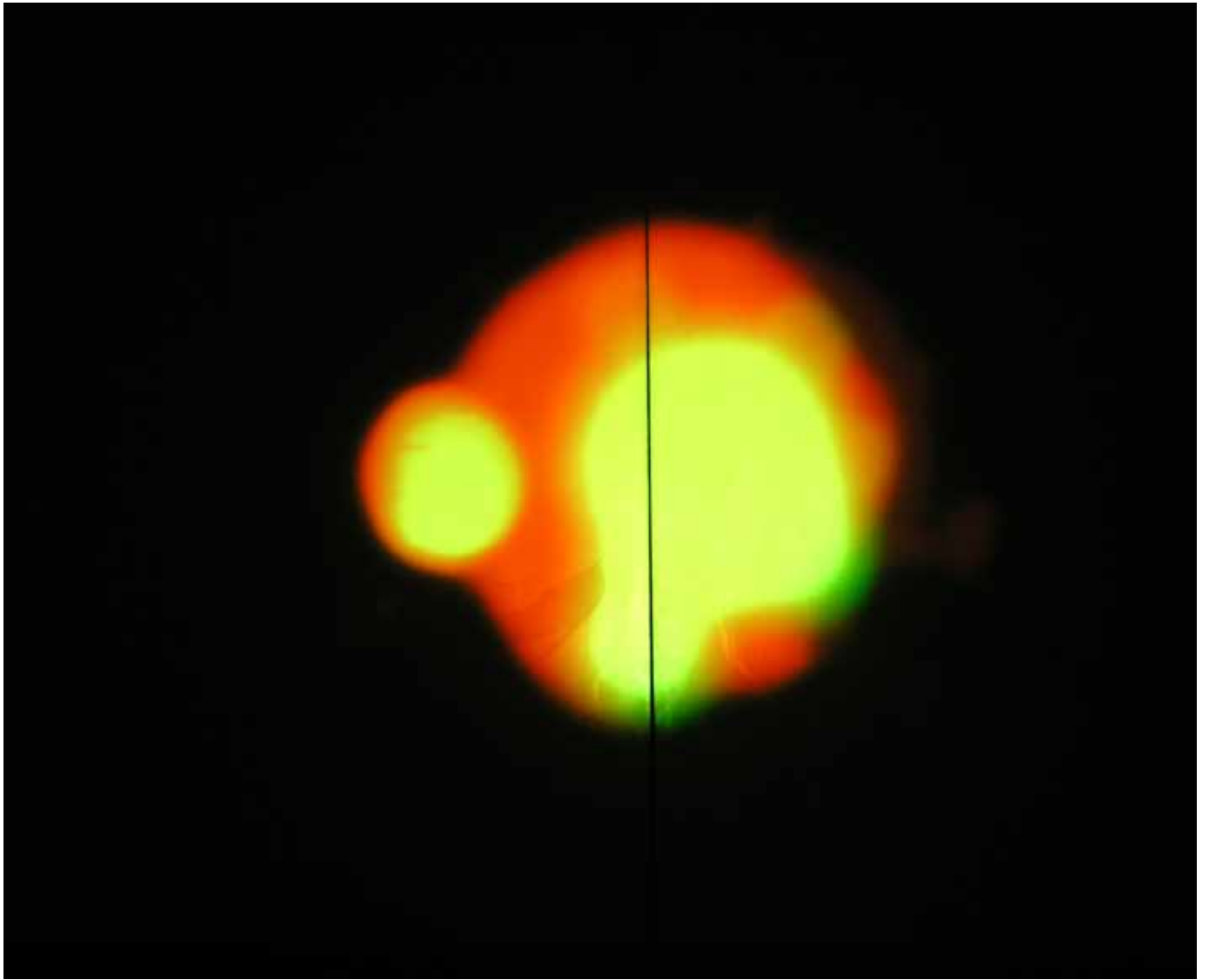









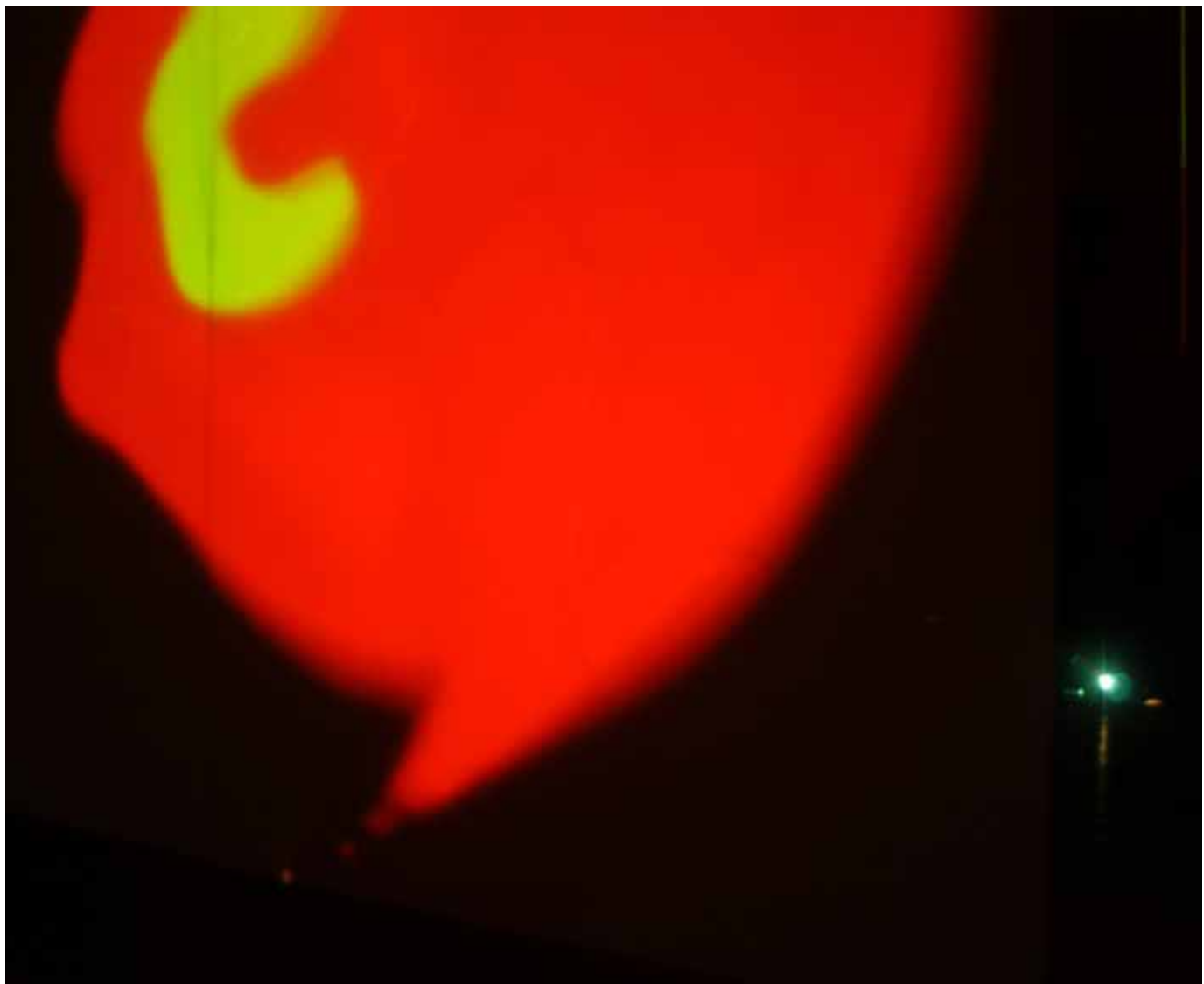

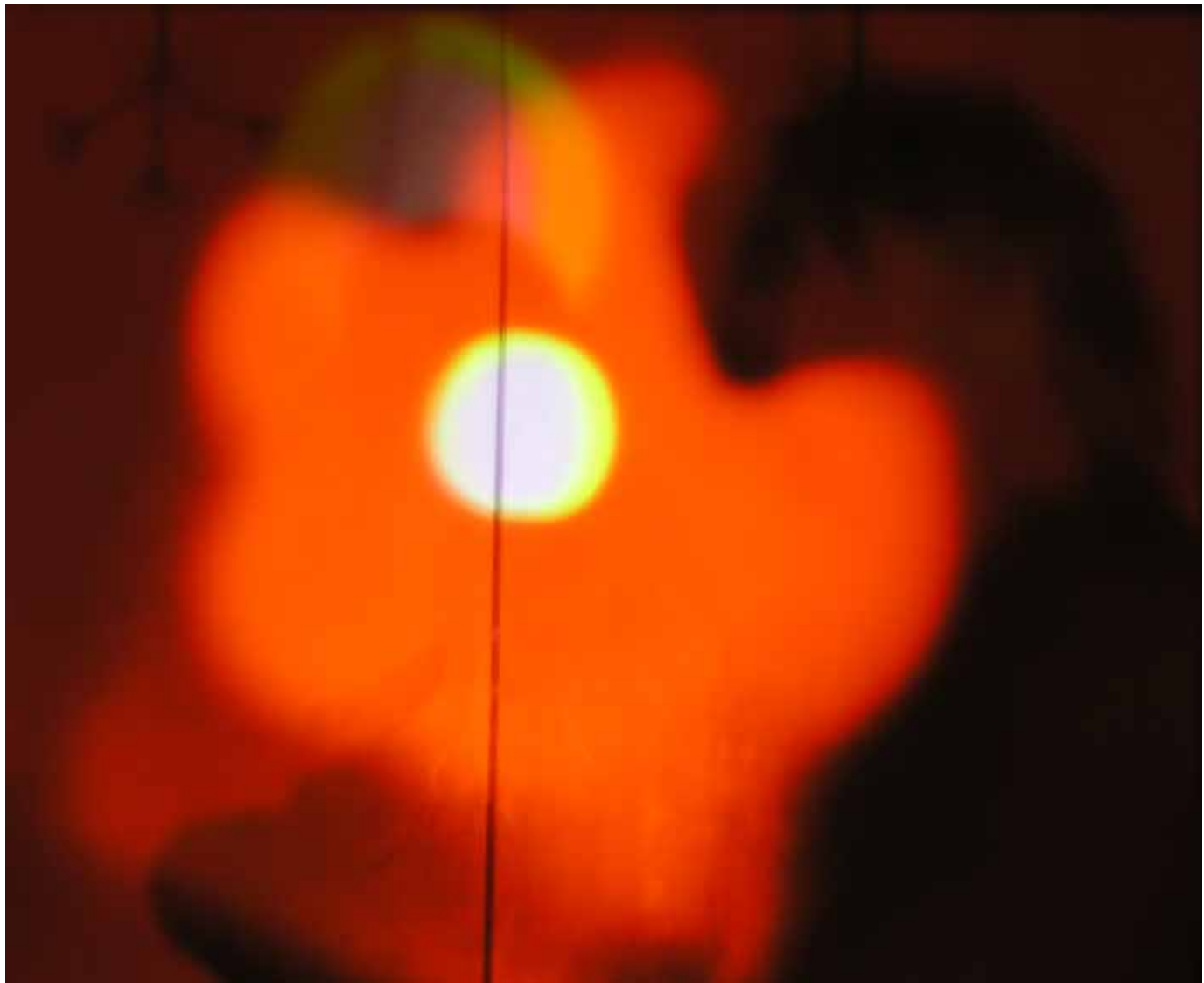

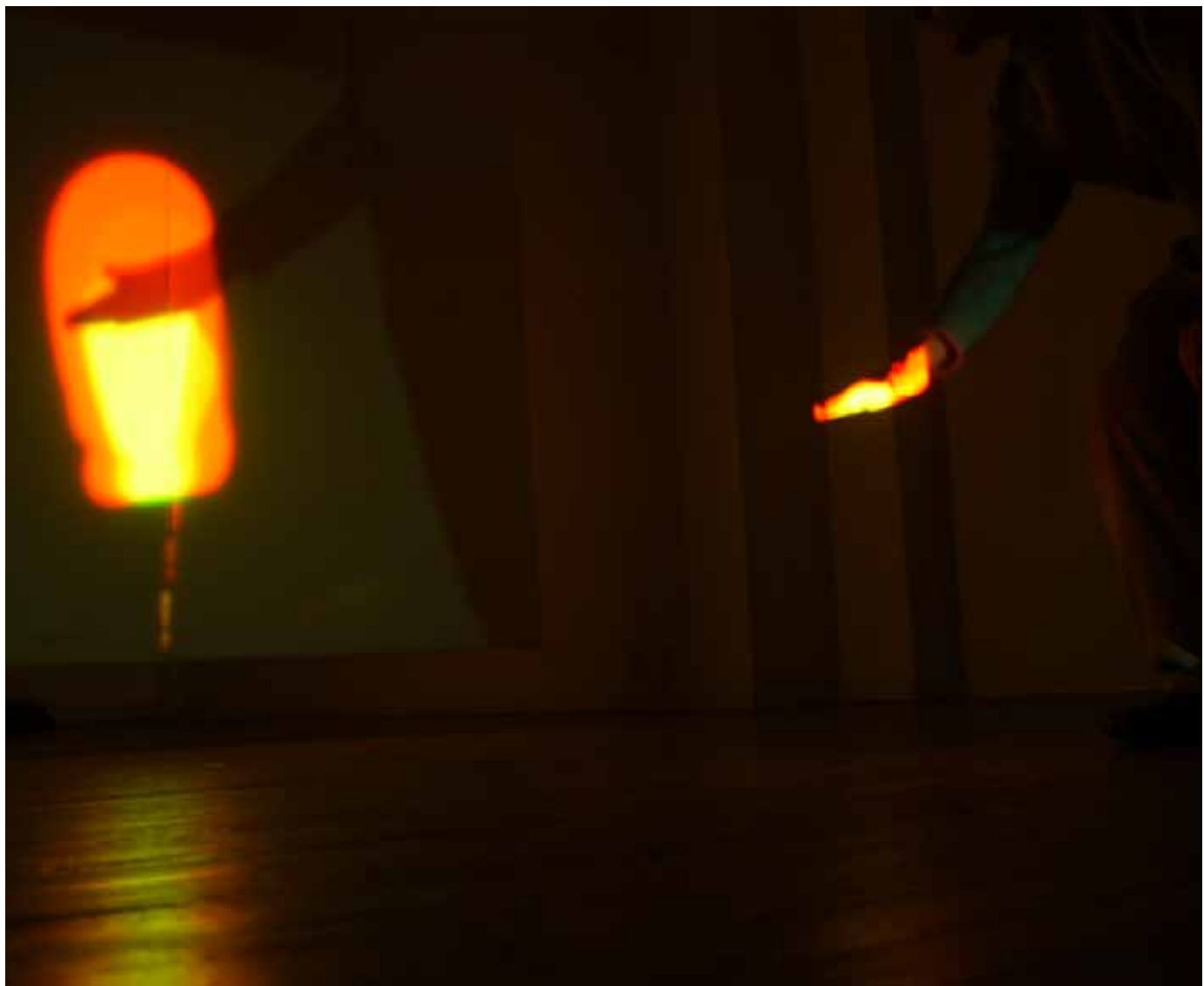

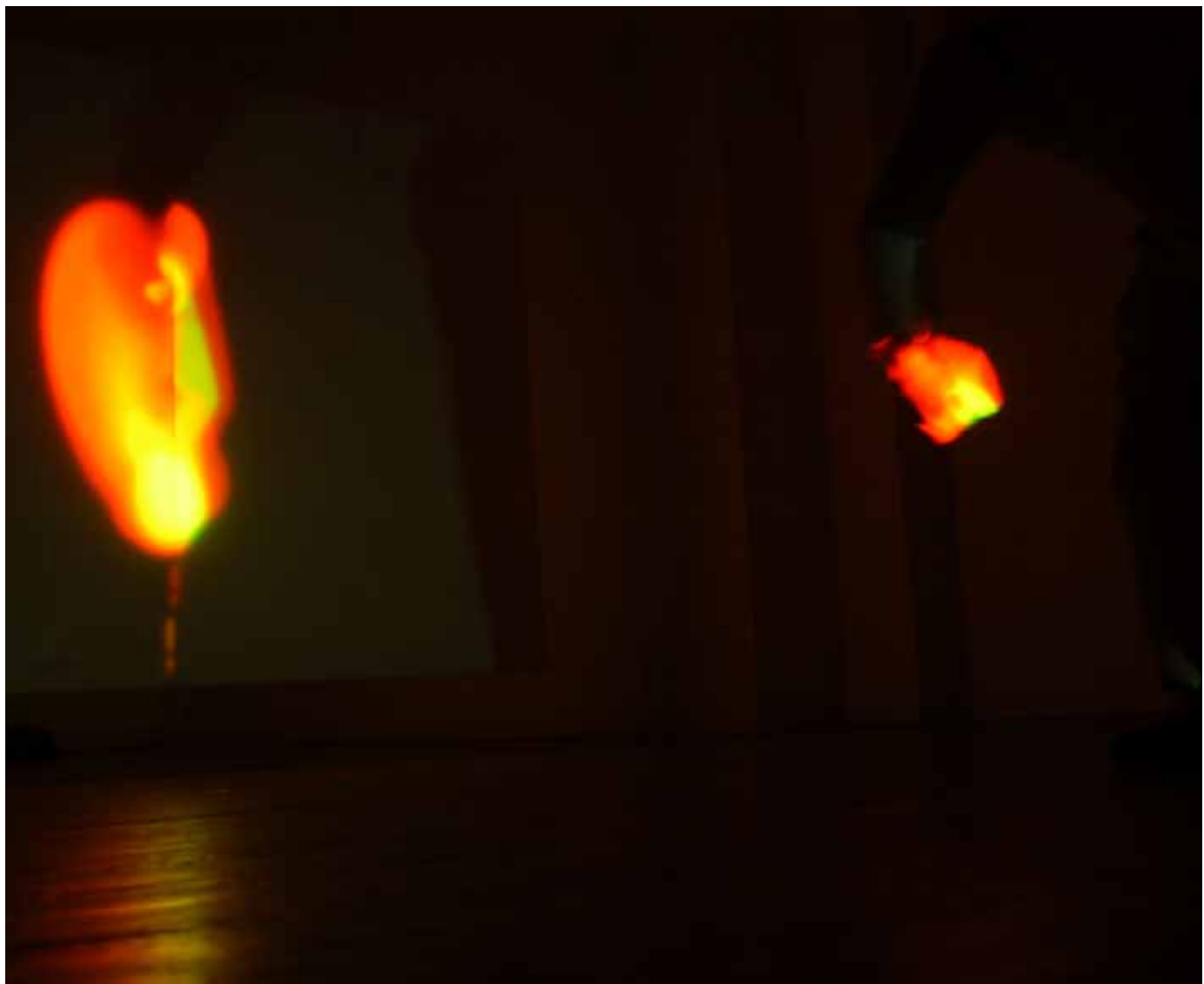

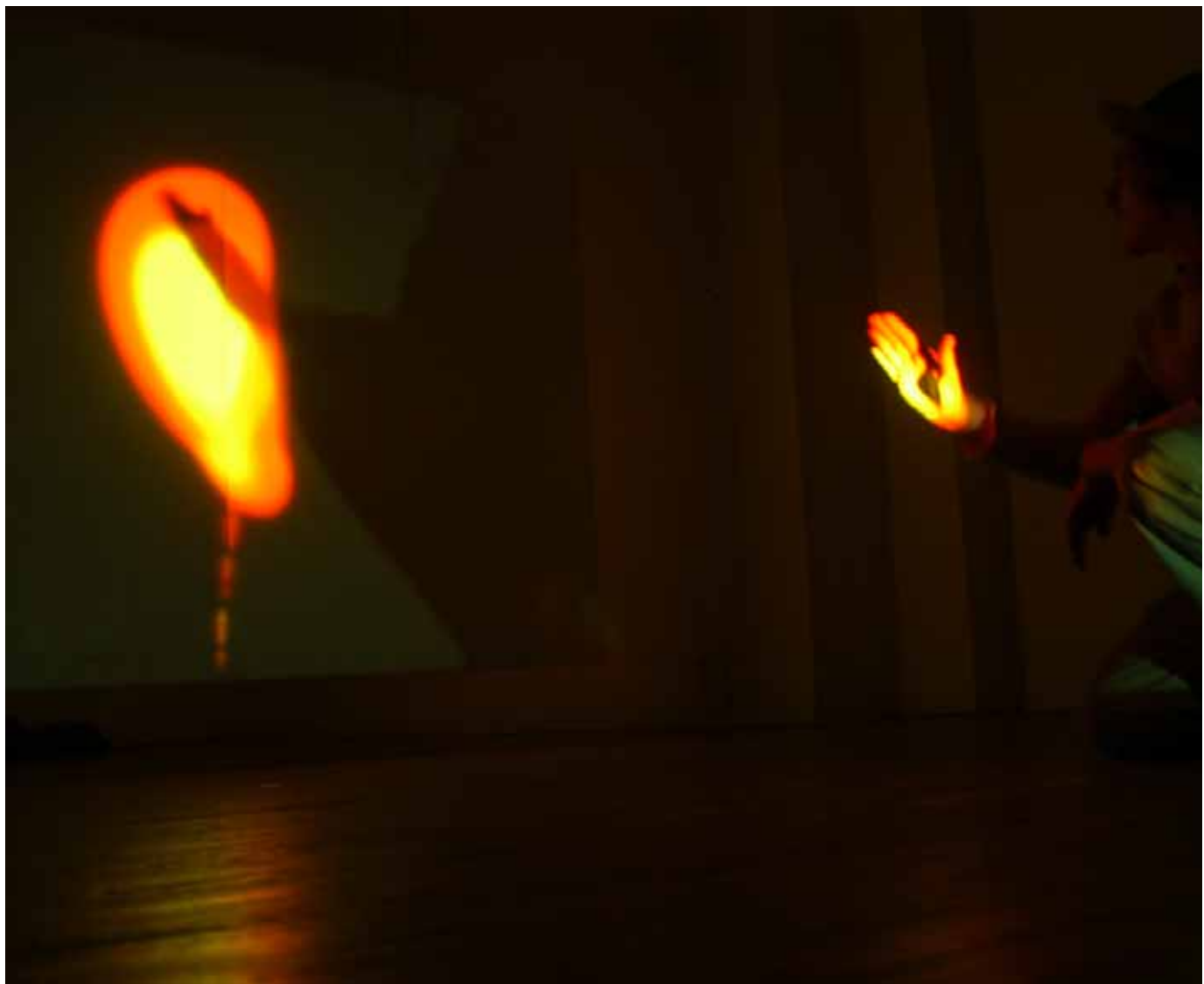

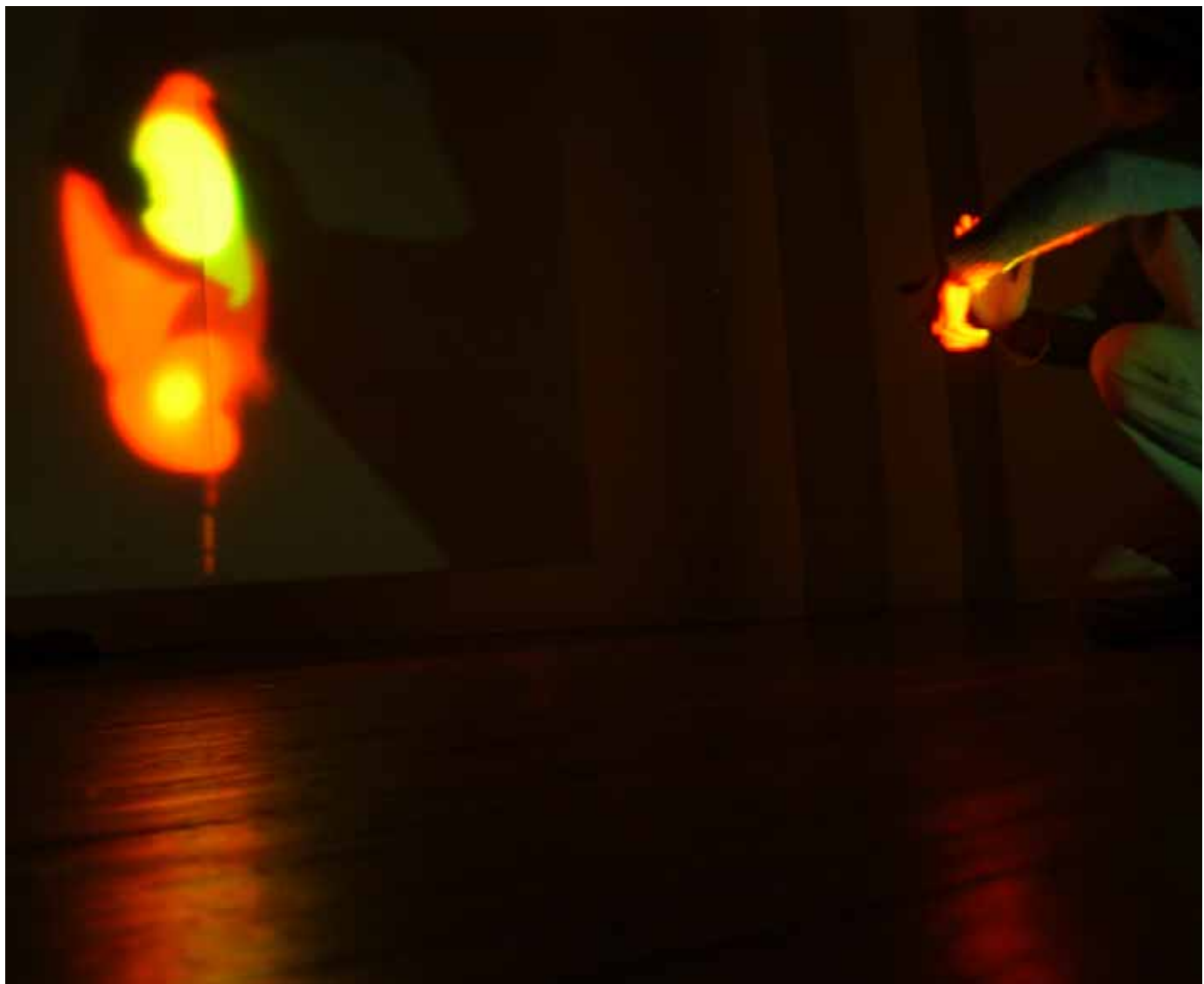





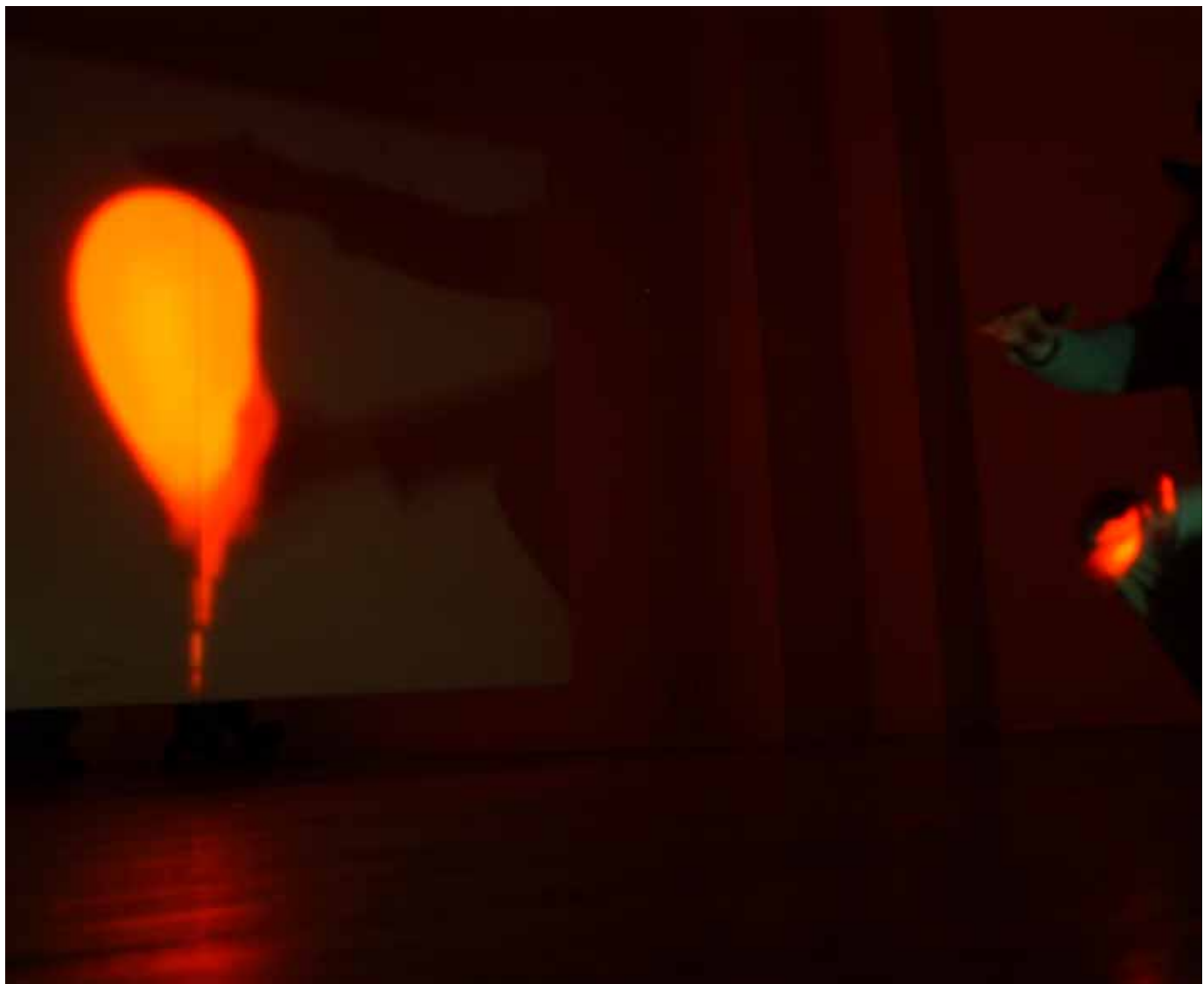







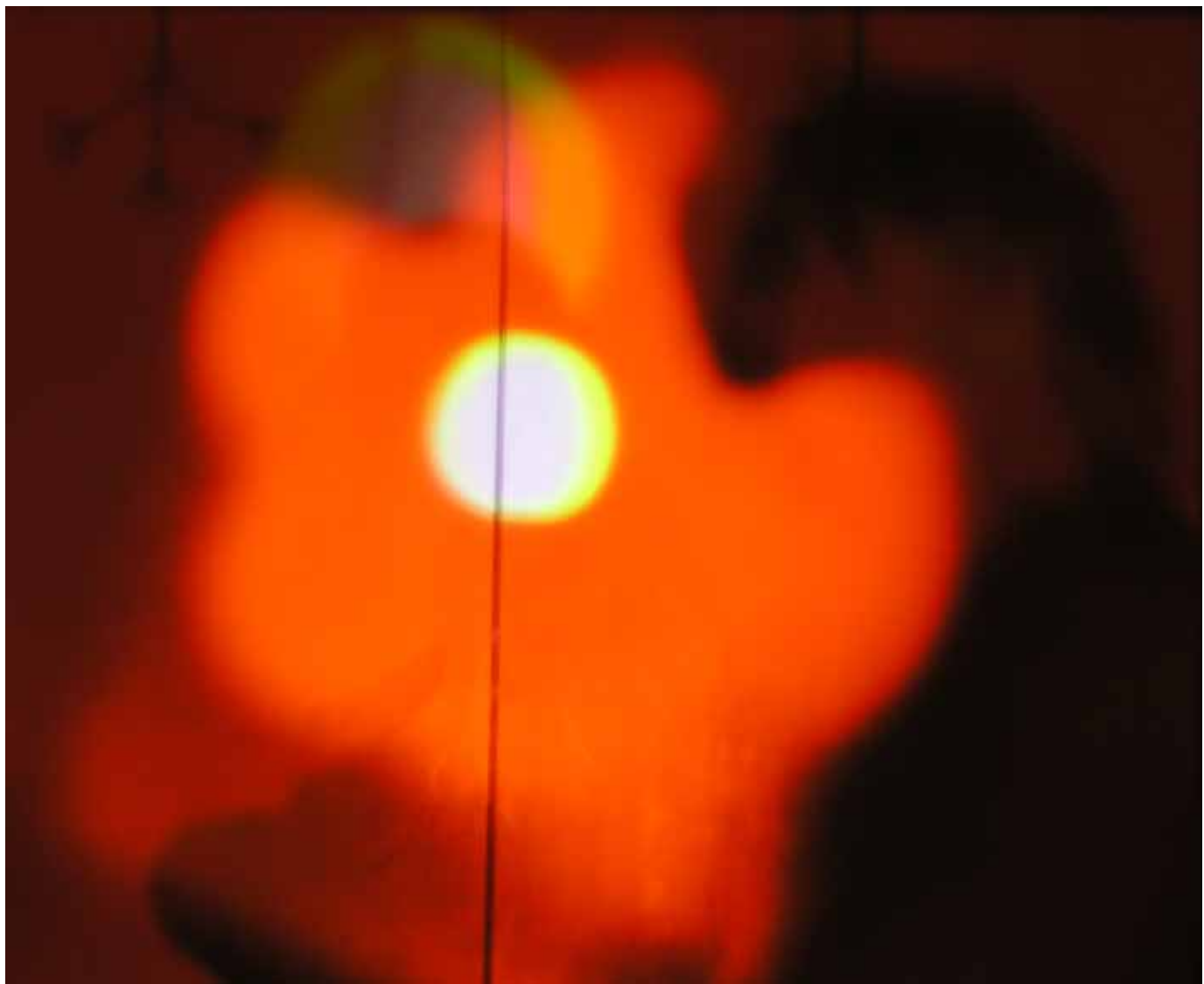

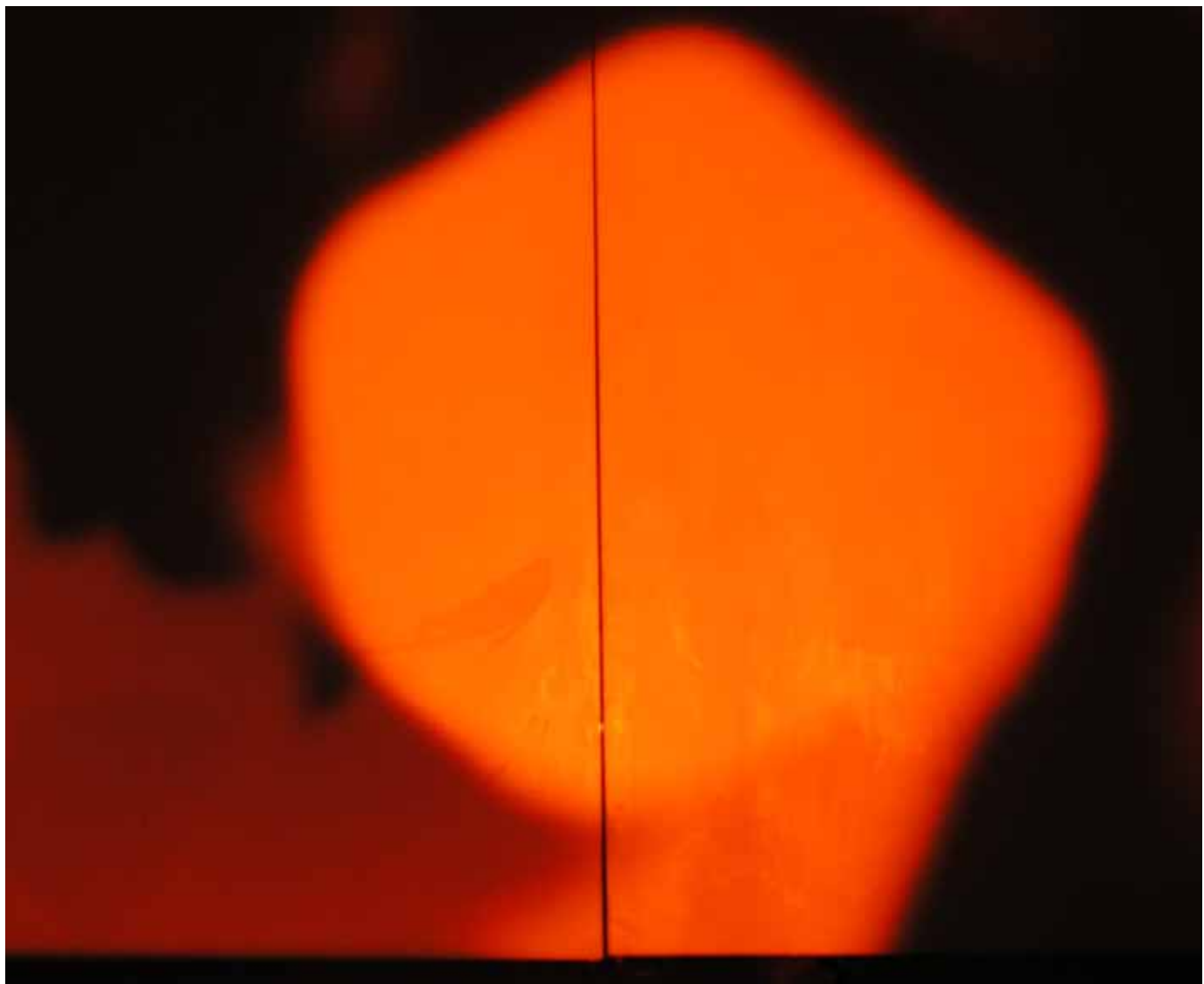

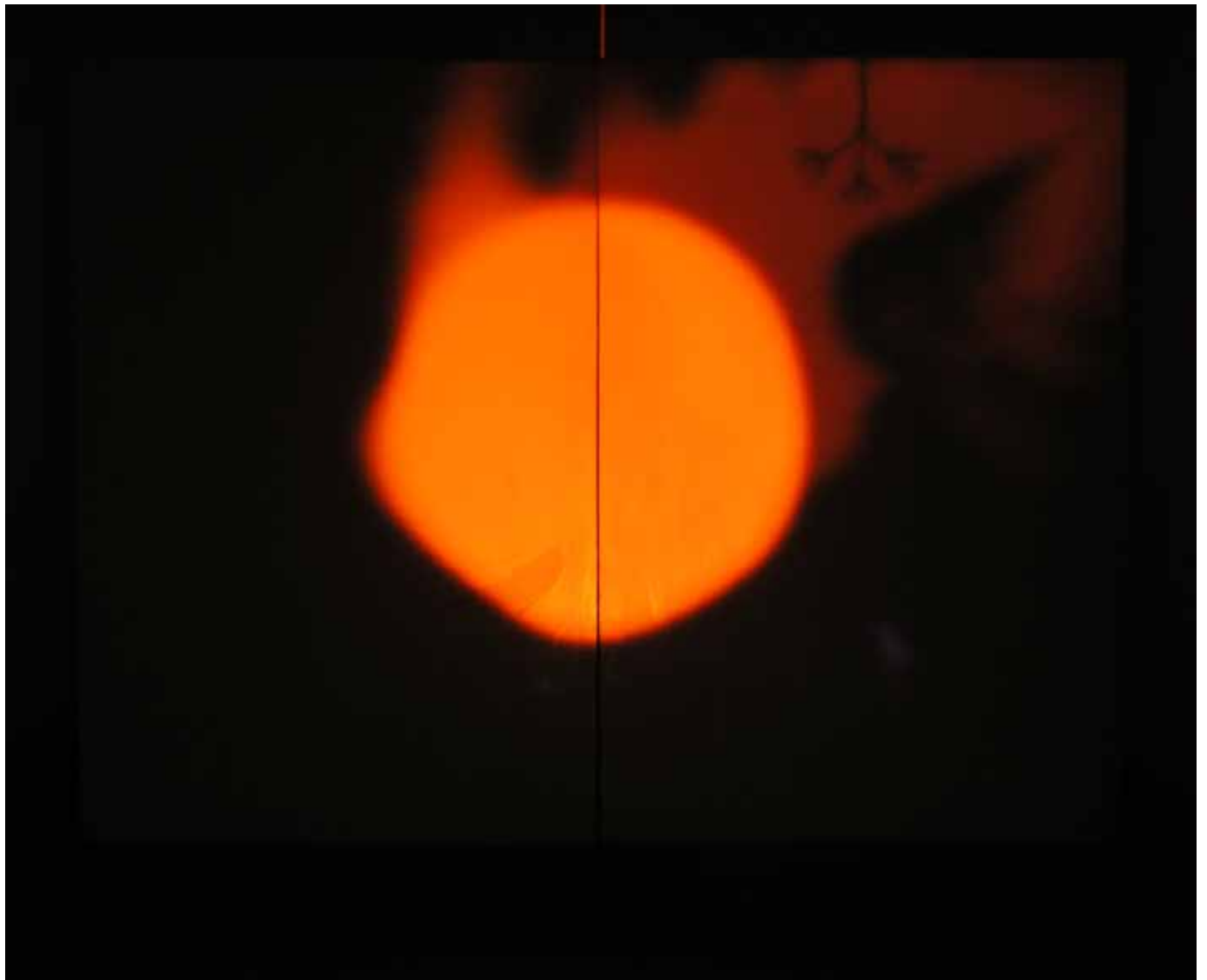



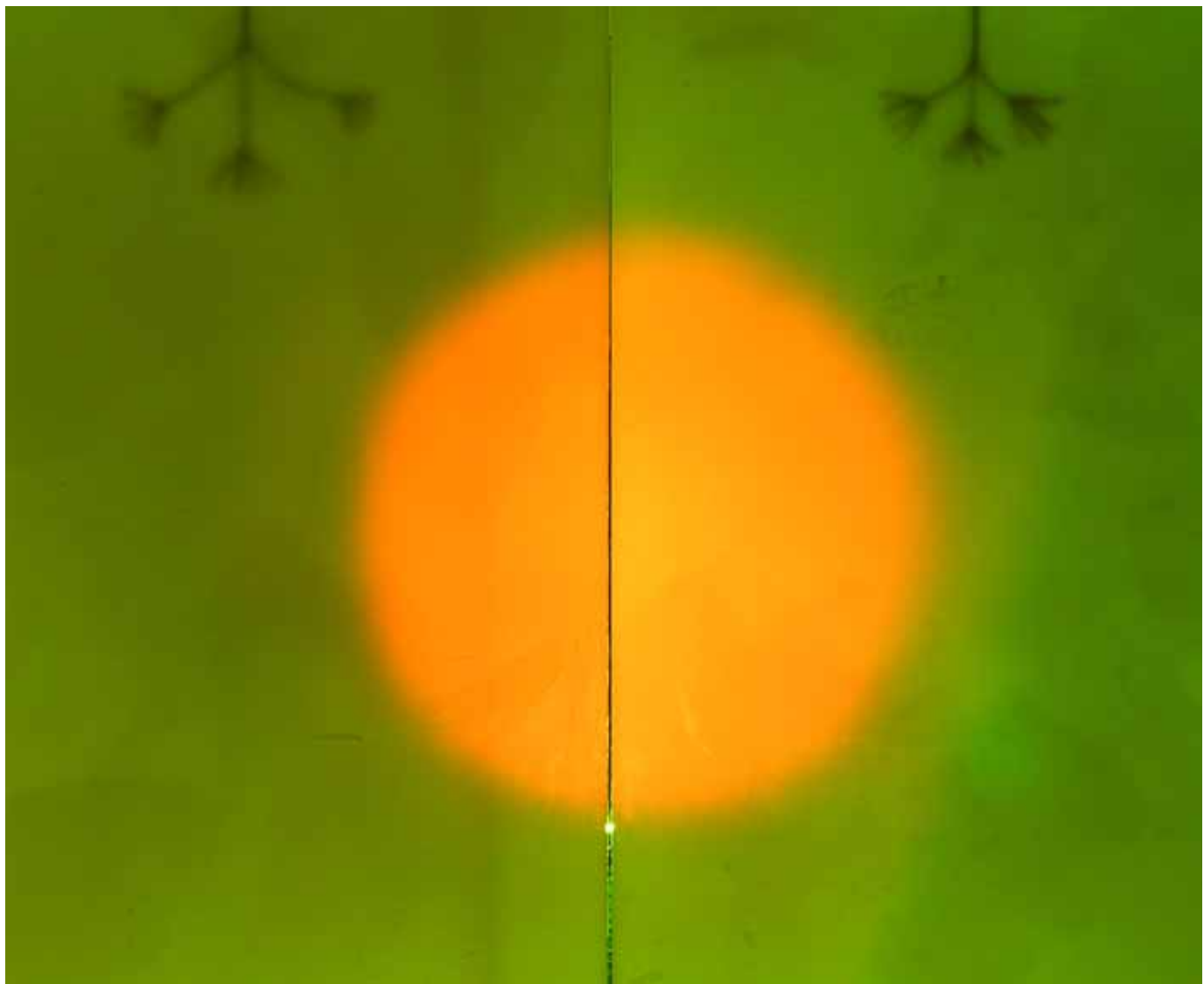



WANDLER

2 WAX DISKS  
2 VIDEO BEAMERS  
2 CAMERAS  
2 SUBWOOFERS  
ENERGY

thanks to

andreas huyskens . axel hartmann . anthony moore . bernd voss . christian  
merscheidt . echo ho . ellen gronwald . florian kuhlmann . frans vogelaar .  
georg schütz . grace lu . hannes hözl . henrike esgen . kaya nowak . kevin  
matweew . kremer pigmente . luis negron . matthias neuenhofer . michael  
van den bogaard . susanne ritter . thomas georgiades

photos: axel hartmann [www.ah-fotografie.de](http://www.ah-fotografie.de)  
andreas huyskens

produced at



Kunsthochschule für Medien Köln  
Academy of Media Arts  
École Supérieure des Arts et Médias



helge jansen . 2005

[www.feldabinda.de](http://www.feldabinda.de)

©copy right or do not

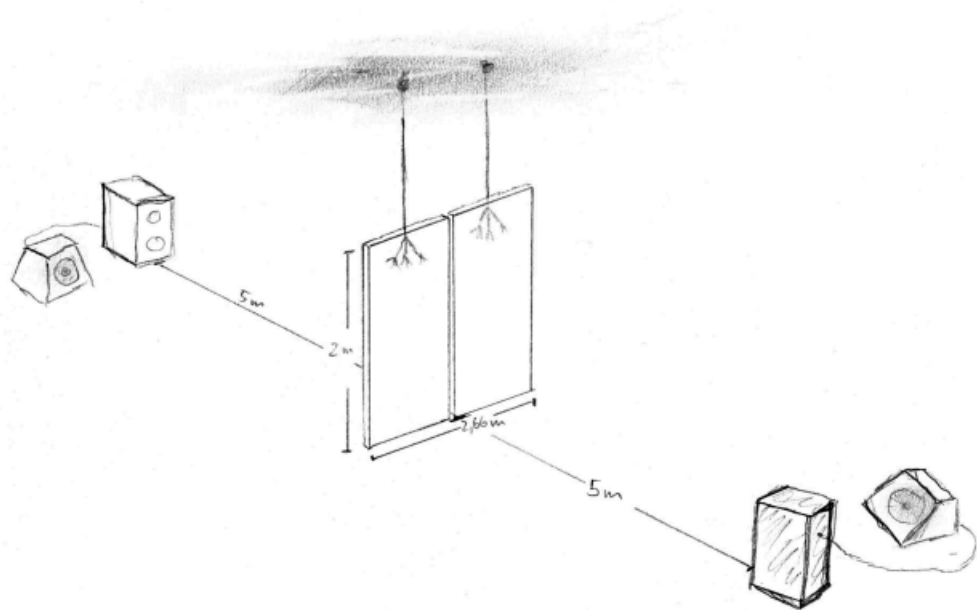

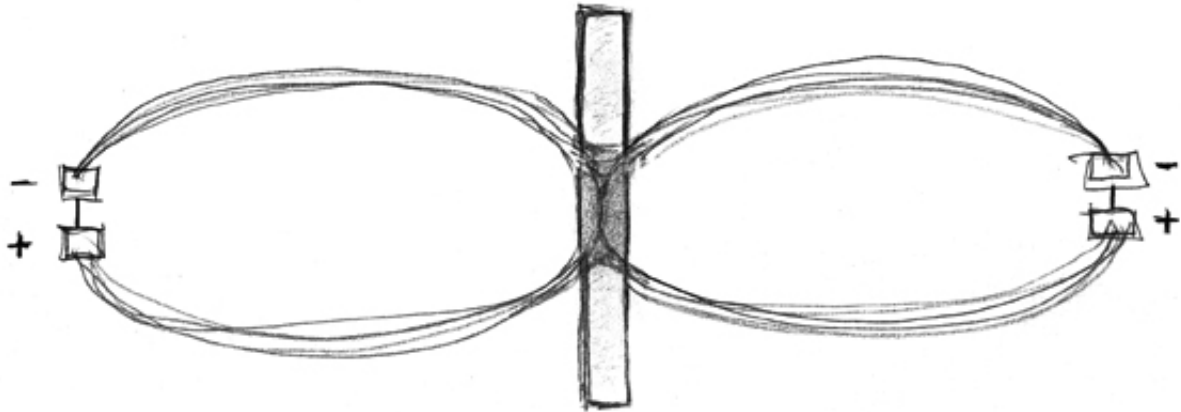

... In other cases the transformation is more hidden and one has to follow certain steps to, for instance, come to the conclusion that energy can be transformed to matter by using the speed of light as a kind of converter, ending up in the fabulous formula of Einstein:  $e = mc^2$ . So we always find a certain medium, simply understood as a temporary carrier, that is necessary to transform information from one manifestation to another. ...

*excerpt from: ,organic media and the strange pullover rule' Helge Jansen, 2005*